

Idle Air Control Systems

The Idle Air Control (IAC) system is used to stabilize idle speed during cold engine and after warm-up operations. Idle speed stabilization is needed due to the effect engine load changes has on emission output, idle quality and vehicle driveability. The IAC system uses an ECM controlled idle air control valve (IACV) that regulates the volume of air bypassed around the closed throttle. The ECM controls the IACV by applying various input signals against an IAC program stored in memory.

There are four different types of IACVs used on Toyota models. These systems are referred to as:

- Step-Motor
- Duty-Control Rotary Solenoid
- Duty-Control Air Control Valve (ACV)
- On/Off Vacuum Switching Valve (VSV)

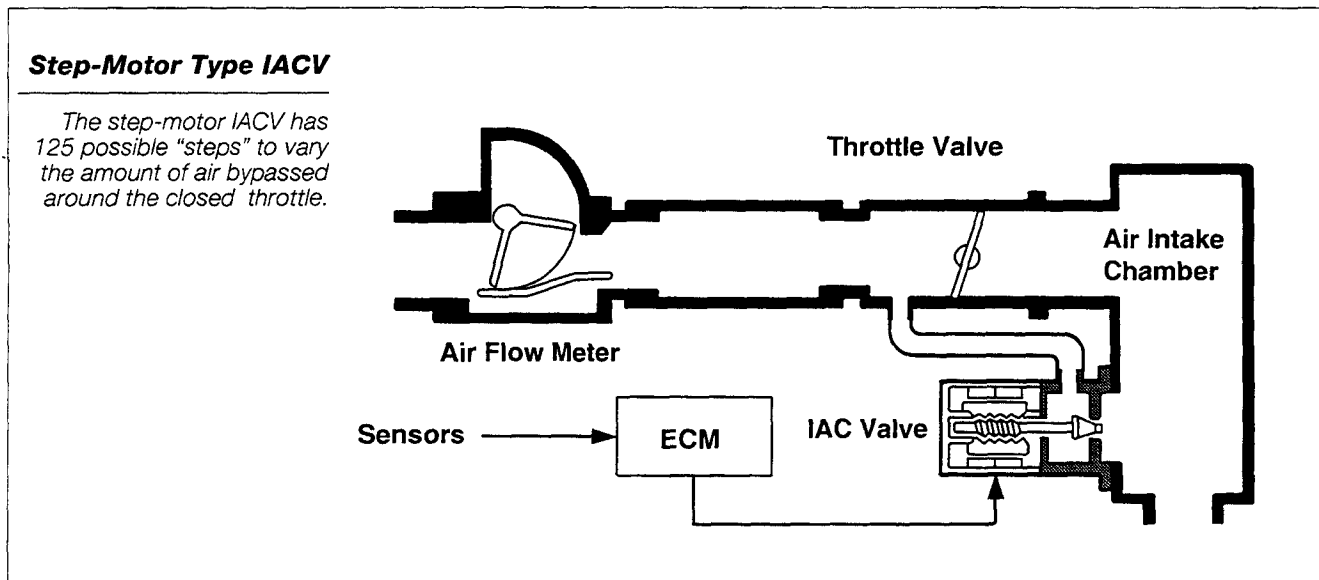

Step-Motor IAC System

This system uses a step-motor type IACV to control bypass airflow. The IACV consists of a step-motor with four coils, magnetic rotor, valve and seat, and can vary bypass airflow by positioning its valve into one of 125 possible "steps". Basically, the higher the IACV step number, the larger the airflow opening and the greater the volume of air bypassed around the closed throttle.

The ECM controls IACV positioning by sequentially energizing its four motor coils. For each coil that is pulsed, the IACV's magnetic rotor moves one step, which in turn changes the valve and seat positioning slightly. The ECM commands larger IACV position changes by repeating the sequential pulses to each of the four coils, until the desired position is reached. If the IACV is disconnected or inoperative, it will remain fixed at its last position.

Duty-Control Rotary Solenoid IAC System

This system uses a rotary solenoid IACV to perform idle speed stabilization. Bypass air control is accomplished by means of a movable rotary valve which blocks or exposes a bypass port based on command signals from the ECM. The IACV consists of two electrical coils, permanent magnet, valve, bypass port, and bi-metallic coil.

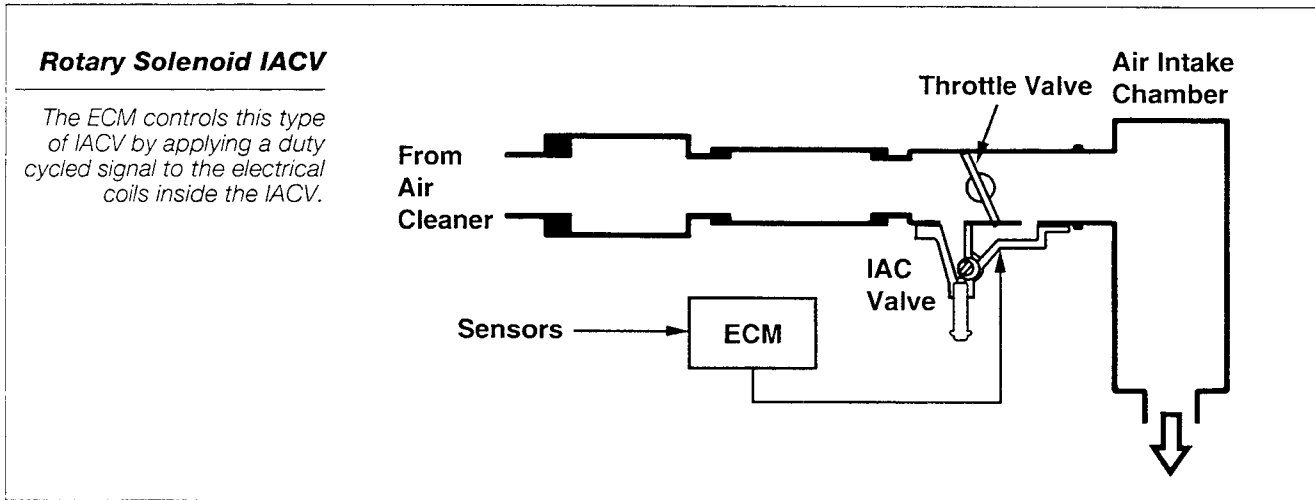

The ECM controls IACV positioning by applying a duty cycled signal to the two electrical coils in the IACV. By changing the duty ratio (on time versus off time), a change in magnetic field causes the valve to rotate. Basically, as duty ratio exceeds 50%, the valve opens the bypass passage and as duty ratio drops below 50%, the valve closes the passage. If the IACV is disconnect or inoperative, the valve will move to a default position and idle rpm will be around 1000 to 1200 rpm at operating temperature.

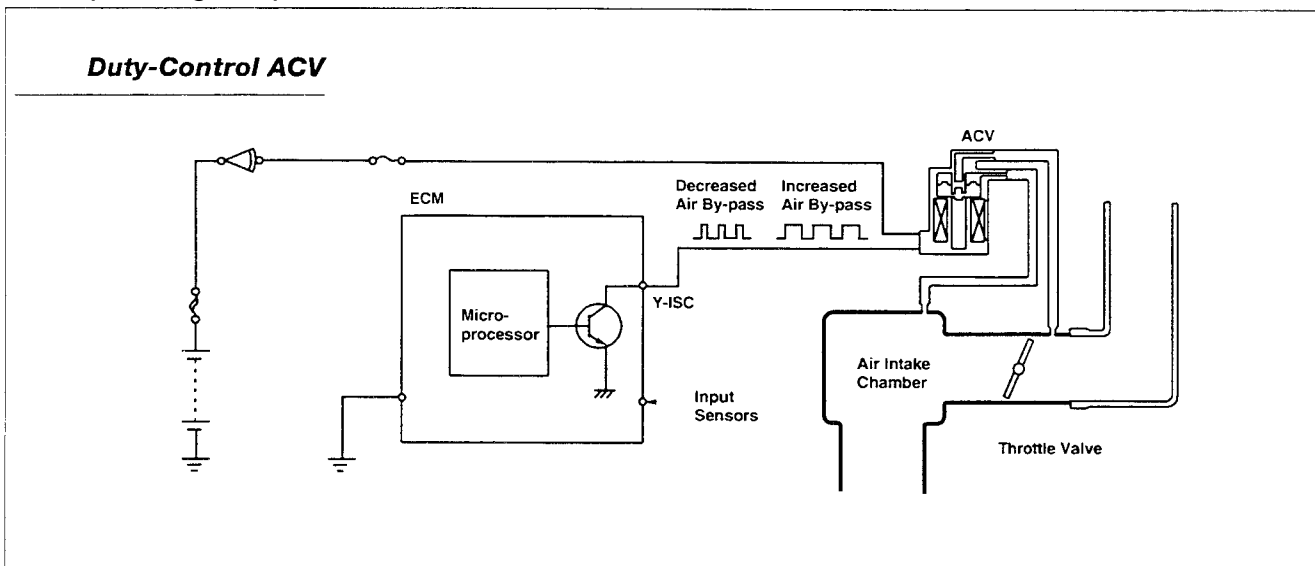

Duty-Control ACV System

This system regulates air bypass volume by using an ECM duty-cycle controlled Air Control Valve (ACV). The ACV uses an electric solenoid to control a normally closed air valve which blocks passage of air from the air cleaner to the intake manifold. Since the ACV is incapable of flowing high air volume, a separate mechanical air valve is used to perform cold fast-idle on

EMISSION SUB SYSTEMS - Idle Air Control Systems

vehicles equipped with this system. With this type system, the ECM varies bypass airflow by changing the duty ratio of the command signal to the ACV. By increasing the duty ratio, the ECM holds the air bypass open longer, causing an increase to idle speed. The ACV does not have any effect on cold fast idle or warm-up fast idle speed, and is only used during starting and warm curb-idle.

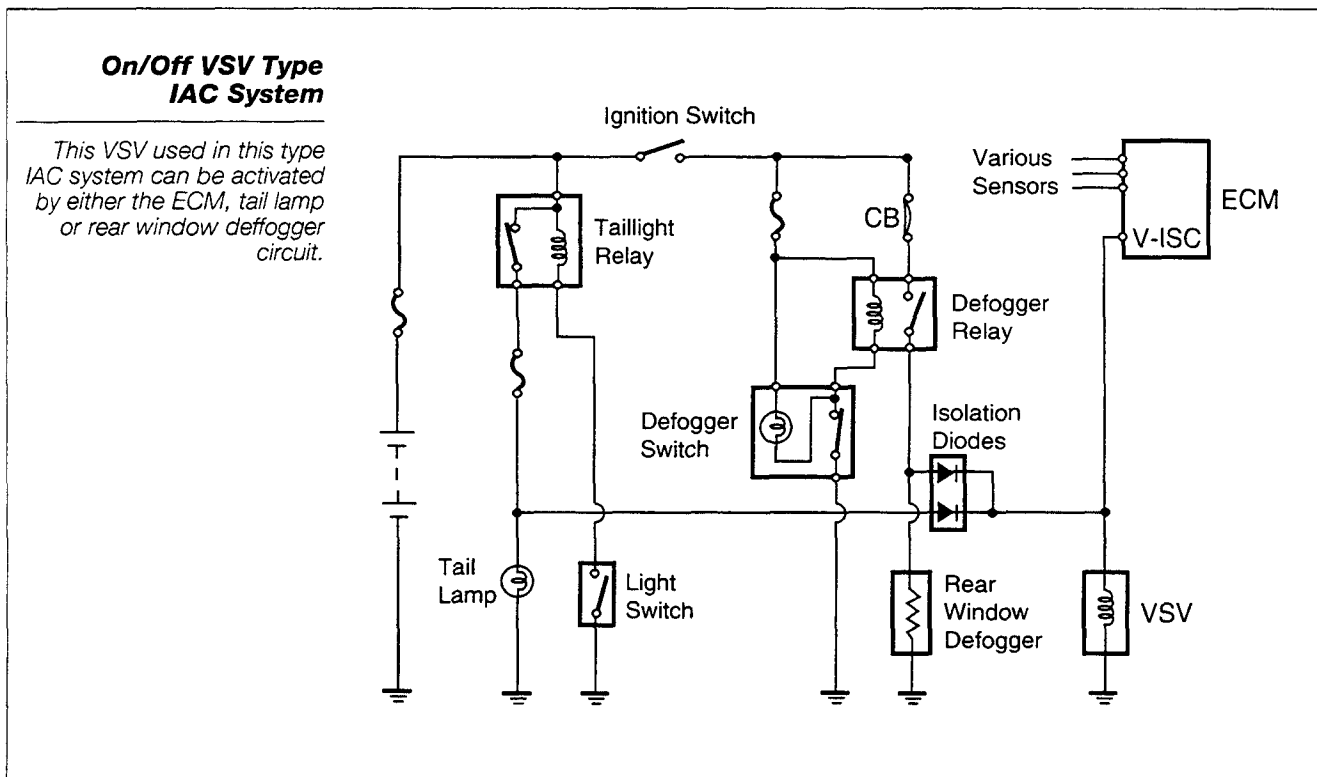

On/Off VSV Type IAC System

This type of IAC system uses a normally closed Vacuum Switching Valve (VSV) to control a fixed air bleed into the intake manifold. This on/off type VSV is controlled by signals from the ECM or directly through the tail lamp or rear window defogger circuits.

The ECM controls the VSV by supplying current to the solenoid coil when preprogrammed conditions are met. Also, current can be supplied to the solenoid from the tail lamp or rear window defogger circuits by passing through isolation diodes. Engines using this IAC system must also use a mechanical air valve for cold fast-idle.

IAC System Control Parameters

Depending on system type and application, the IAC system may perform a combination of the following control functions; initial set-up, engine startup, warm-up control, feedback idle control, engine speed estimate control, electric load idle-up, learned idle speed control, and A/T idle-up control. Refer to course 850 handbook for specific details concerning the operating parameters for each of the IAC systems.

Air Valves

There are two types of non-ECM controlled air valves that are used on some engines to perform cold fast-idle control. The first type simply uses a thermo-wax element to vary the amount of bypass air based on the coolant temperature. Once the engine reaches operating temperature, the air valve should be fully closed.

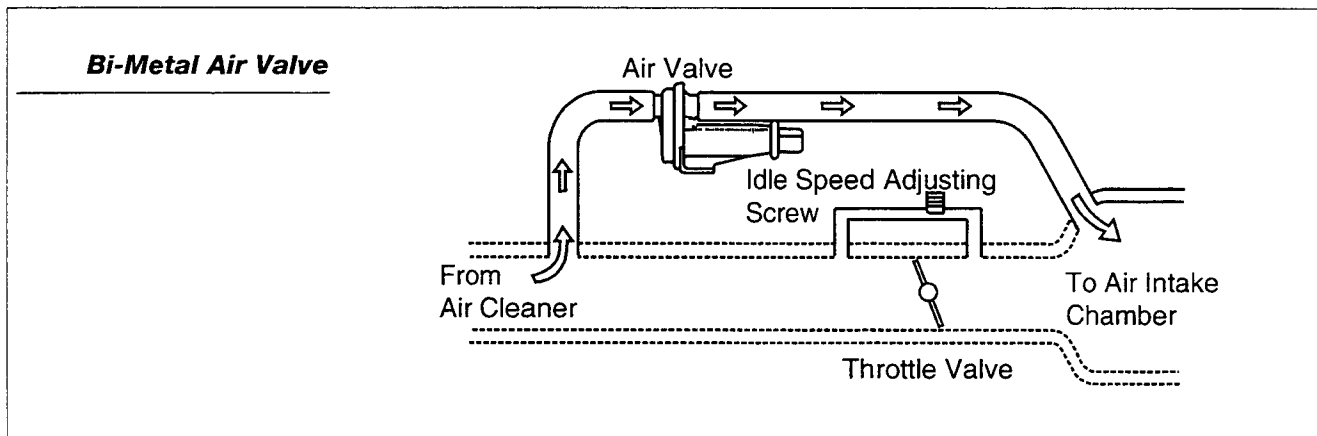

The second type uses a spring loaded gate balanced against a bi-metal element. As engine temperature rises, the bi-metal element deflects to close the gate valve, thereby reducing the amount of bypass air. A heater coil surrounds the bi-metal element and is used to heat the element whenever the engine is running (fuel pump operates). An air valve quick check can be performed by pinching off the supply hose and observing rpm drop. The drop should be less than 50 rpm when the engine is warm, and should be significantly higher when the engine is cold.

EMISSION SUB SYSTEMS - Idle Air Control Systems

Effects of IAC Operation on Emissions & Driveability

Improper operation of the IAC system can have significant impact on idle quality and driveability. If idle speed is too low, the engine may stall or idle very rough. If idle speed is too high, harsh A/T gear engagement may result.

On some IAC systems, the IACV step count or ECM duty ratio may provide hints as to whether a major correction is being made to offset a idle speed problem. For instance, if false air entry causes idle speed to be much higher than normal, the IAC system may correct for this condition by decreasing bypass air volume in an effort to bring idle speed back to the "target" idle speed.

The IACV step count or duty ratio may also identify a restricted air passage, misadjusted throttle, or IAC valve problem. Observe IAC signal data at idle, while applying various "loads" to the engine. Look for a corresponding change to IACV step count or duty ratio, as loads are placed on the engine. Also, a signal comparison to other known good vehicles may be helpful.

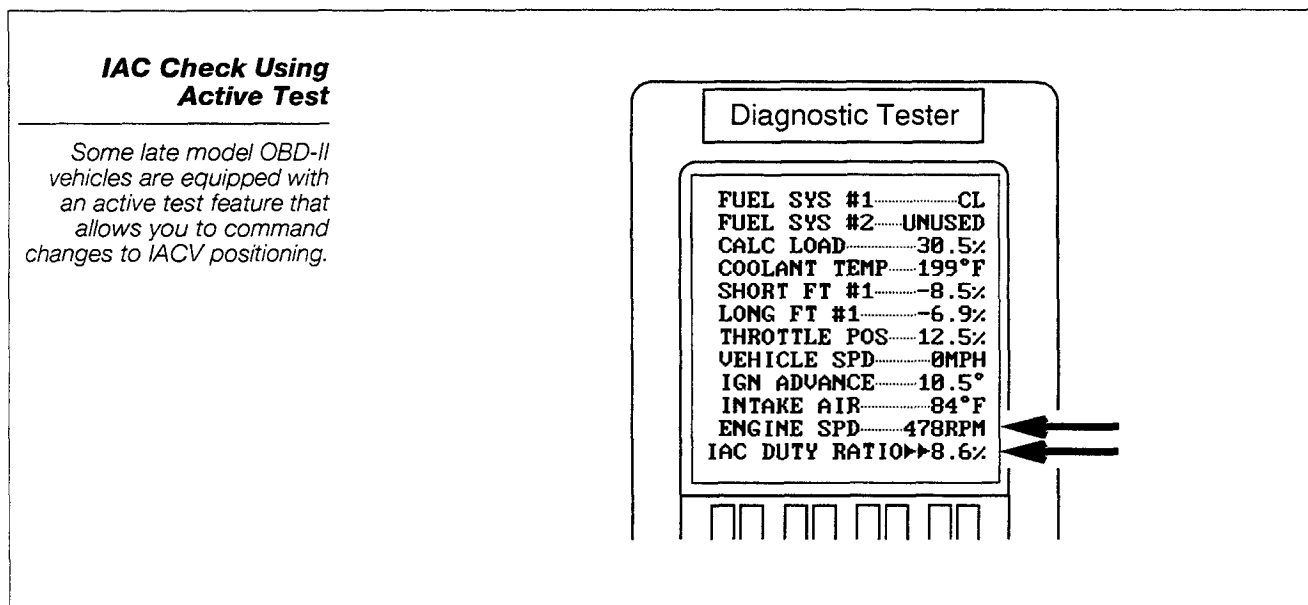

IAC System Functional Tests

Because functional checks vary between the four major types of IAC systems, refer to the Repair Manual for specific procedures on performing an on-vehicle IAC inspection. On some late model OBD-II vehicles, an active test feature will allow you to manually command IACV positioning from fully open to fully closed. A quick check can be made by commanding a change to IACV positioning while watching for expected changes to idle rpm.